

Explosion Proof Peristaltic Pump

Model No.: ExD-600-12L/DY35

Flow Rate: 2.25-12740mL/min



Product Introduction

- A new category of peristaltic pump based on explosion proof standards.
- The whole pump is explosion proof, reaching Ex II2G Ex db IIC T4 Gb and Ex II2D Ex tb IIIC T130°C Db explosion proof levels at the same time.
- Intelligent control system to realize high precision transferring and dispensing.

Product Features

1. Integrated casting body .
2. IP66 designed for industrial environment.
3. Three-proof buttons and knob system: explosion-proof dustproof, waterproof.
4. Intelligent operation system.
5. Passed EMC test excellent anti-electromagnetic interference capability.
6. AC servo motor control system.
7. Laser engraving logo pattern to eliminate the hidden danger of static electricity of traditional plastic label.

■ Main Interface

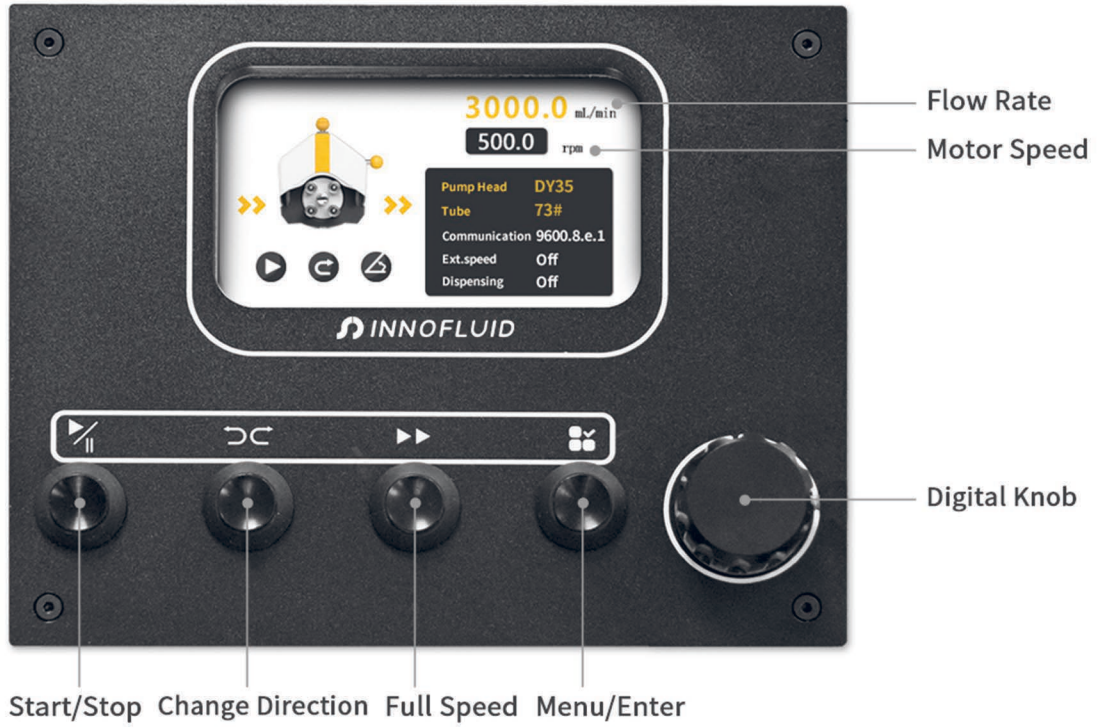

■ Pump Head



DY35

Flow Rate

Drive	Pump Head	Housing Material	Tubing		mL/r	Speed(rpm)	Flow Rate(mL/min)	Weight(kg)
			Size	IDxWall Thickness(mm)				
ExD-600-12L	DY35	Aluminum alloy	73#	9.6x3.3	22.5	0.1-350	2.25-7875	10.6
			82#	12.7x3.3	26.4		3.64-12740	



DY35 Filling Volume Reference Parameter

Drive	Pump Head	Tubing	Filling Volume(mL)	Filling Time(s)	Accuracy(±%)	Output(pcs/min)	Motor Speed(rpm)
ExD-600-12L	DY35	73#	300	3	0.5	15	245.1
		82#	500	3	0.5	15	269.2

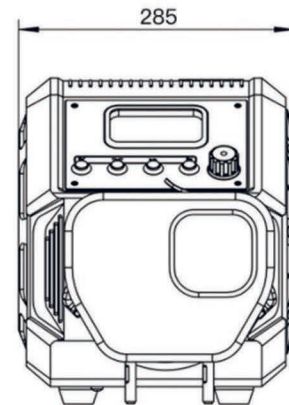
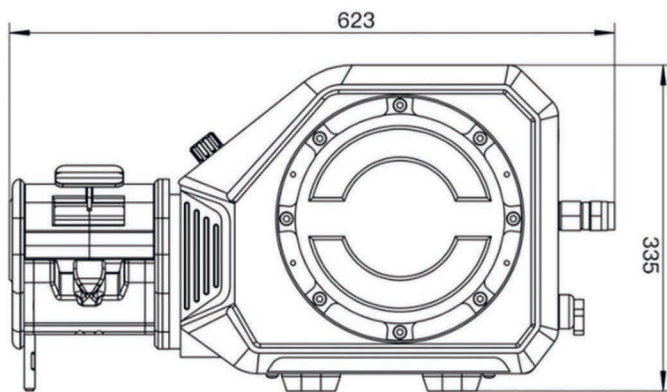
Dimension Drawing(Unit:mm)



Technical Specifications

Marking	 II2G Ex db IIC T4 Gb  II2D Ex tb IIIC T130°C
Standard	EN IEC 60079-0:2018+A11:2024; EN IEC 60079-1:2014+A11:2024; EN IEC 60079-31:2018
Housing material	Aluminum Alloy
Speed range	0.1-350rpm
Speed resolution	0.1rpm
Display	4.3 inch-Industrial grade-True color LCD screen
Control	Mechanical button, explosion proof knob, external control signal and communication
Working mode	Flow rate mode, Dispensing mode
Flow rate mode	Continuous transferring according to the set flow rate or motor speed
Dispensing mode	Set the dispensing volume, dispensing time, pause time and repeat numbers
Dispensing volume	0.1mL-9999L
Dispensing time	0.1sec-9999hour
Pause time	0.5sec-9999hour
Repeat number	1-9999 times, 0 represent unlimited
Calibration function	Input actual volume and calibrate automatically
Back suction angle	0-360°
Communication	RS485
Communication protocol	Modbus protocol(RTU mode)
External control speed signal	0-5V, 0-10V, 4-20mA optional
External control signal input	Active switch signal (5-24V) control start/stop, direction and full speed; Passive switch signal control start/stop.
External control signal output	Open collector output working status
Drive dimension (L×W×H)	623x285x335mm
Power supply	AC220V±10%, 50Hz
Rated power	300W
Relative humidity	<90%
Condition temperature	0-40°C
IP rate	IP66
Drive weight	30.1kg