

High Pressure Pump Head

Model No.: OEM-GYB201

Flow Rate :: 0.0855-513mL/min

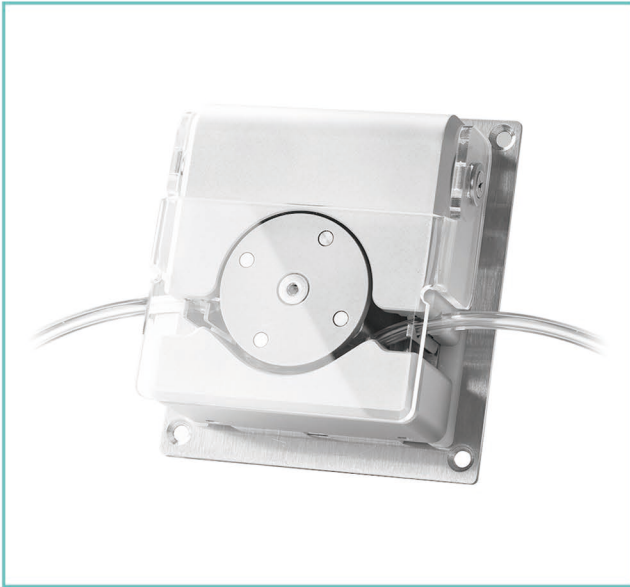

Product Features

The GY15 is designed for surgical cooling applications such as radiofrequency and microwave ablation. It delivers precise fluid control in medical applications, enabling accurate fluid delivery. The pressure-flow curve can be finely adjusted according to the requirements of each specific application. It supports flow rates up to 513 mL/min and pressures up to 0.8 MPa.

Product Features

- Maximum pressure up to 0.8 MPa with stable output.
- Quick and convenient tubing replacement.
- Precision-machined for high performance and long service life.
- Easy-to-clean surface.

Motor Specification

Speed range	0-600rpm
Flow rate range	0-513mL/min
Motor type	57stepper motor
Motor phase numbers	2
Motor step angle	1.8°
Motor phase voltage	1.8V
Motor phase current	3.0A
Working ambient	0-40°C, < 80%RH, non-condensing

Flow Rate

Model	Housing material	Tube clamp material	Tubing		(Speed: 0-600rpm) Flow rate range(mL/min)	Weight (Kg)
			Tubing No.	IDxWT (mm)		
GY15	Aluminum alloy	Stainless steel	14 [#]	1.6x1.6	0-153	0.95
			19 [#]	2.4x1.6	0-306	
			16 [#]	3.1x1.6	0-513	

Dimension Drawing (Unit:mm)

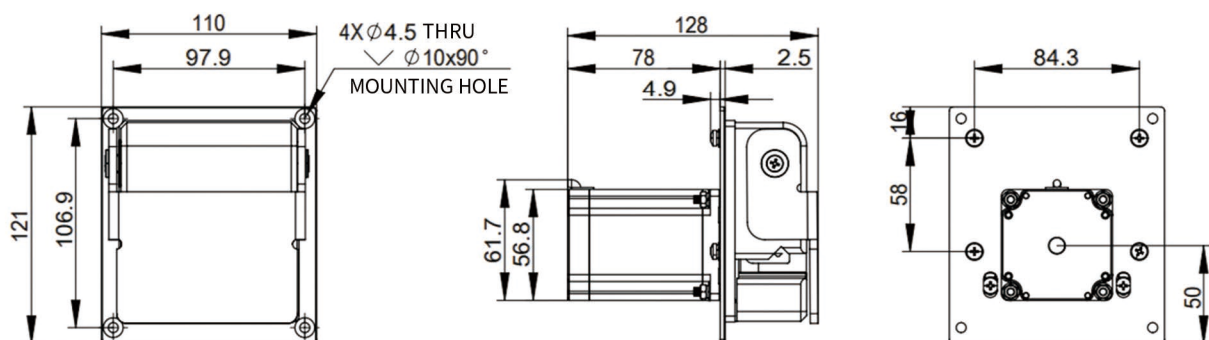

Tubing Installation



1. Open the pump head front cover upward.



2. Place the tubing between the rollers and the upper pressure block, then insert both ends into the tube clamps on each side.

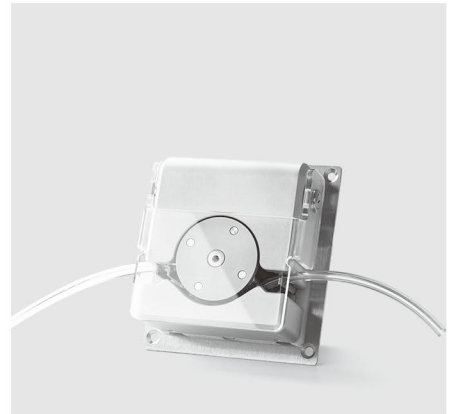

3. Close the pump head front cover downward.